

# FLOW TOP RGBW

Our FAZE FLOW TOP is a high quality, flexible extruded silicone strip. It is ideal for use along ceilings, walls, cabinetry & stairways; both indoors and outdoors. This strip will ensure a seamless combination of style and functionality to any project!

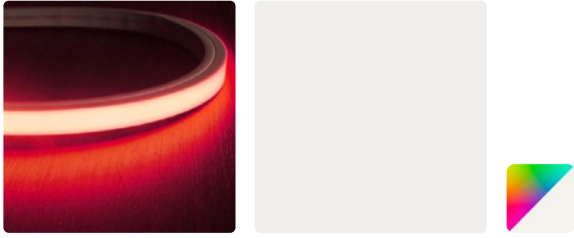

## FEATURES

- + Top Emitting Light Direction, For Application Requiring Direct Light.
- + UV & Chemical Resistant.
- + Precise Cutting Options.
- + High CRI – Excellent Colour Rendering.
- + Compatible With Casambi Devices.
- + IP 67 – Suitable for Outdoor Applications.
- + Front, Side, and Bottom Cable Entry Connection Options.



## GENERAL SPECIFICATIONS

|                  |                    |    |       |
|------------------|--------------------|----|-------|
| LED              | 15W/m              |    |       |
| Lumens           | 426 Lm             |    |       |
| Efficacy         | 56 Lm/W            |    |       |
| Colour           | RGBW               |    |       |
| Material         | Extruded Silicone  |    |       |
| Finish           | White              |    |       |
| Beam             | CRI                | IP | White |
| Colour Deviation | 120°               |    |       |
| Lifetime         | 92+                |    |       |
| Warranty         | 67                 |    |       |
| Voltage          | SDCM ≤2            |    |       |
|                  | >54,000hrs L70 B10 |    |       |
|                  | 5 Years            |    |       |
|                  | DC 24V             |    |       |

## PROJECT DETAILS

PROJECT:

TYPE:

NOTES:

## DIMENSIONS

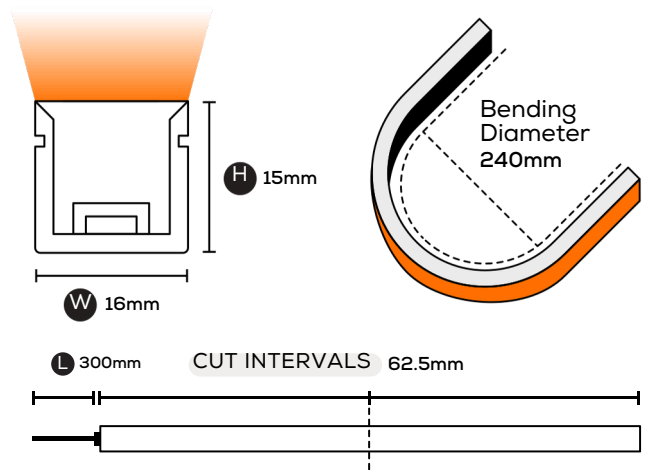

## CUTTING LENGTHS

62.5mm Increments Up Until 5m. Please Allow 9mm extra on each side for the end caps.

## PRODUCT CODES

RGBW 10-FL1615TRGBW

## COMPATIBLE CASAMBI DEVICES

|                   |              |
|-------------------|--------------|
| BasicDIM 24V 150W | 71-CAS24V150 |
| BasicDIM 24V 100W | 71-CAS24V100 |
| BasicDIM 24V 60W  | 71-CAS24V60  |
| BasicDIM 24V 35W  | 71-CAS24V35  |

espo  
LIGHTING

espo.com.au  
ABN 53 136 770 566

[joseph@espo.com.au](mailto:joseph@espo.com.au)  
+618 8117 8633

# ACCESSORIES

## SIDE CABLE ENTRY



|                   |                          |
|-------------------|--------------------------|
| <b>Order Code</b> | 10 – FL1615RGBWPSE       |
| <b>Dimensions</b> | 27.9mm x 20.4mm x 19.4mm |
| <b>Finish</b>     | Transparent              |

## ALUMINIUM PROFILE



|                   |                          |
|-------------------|--------------------------|
| <b>Order Code</b> | 10 – FL1615P1            |
| <b>Dimensions</b> | 1000mm x 17.3mm x 21.1mm |
| <b>Material</b>   | Aluminium                |

## REAR CABLE ENTRY



|                   |                          |
|-------------------|--------------------------|
| <b>Order Code</b> | 10 – FL1615RGBWPPE       |
| <b>Dimensions</b> | 27.9mm x 20.4mm x 19.4mm |
| <b>Finish</b>     | Transparent              |

## MOUNTING CLIPS



|                   |                        |
|-------------------|------------------------|
| <b>Order Code</b> | 10–FL1615MC            |
| <b>Dimensions</b> | 20mm x 12.6mm x 18.9mm |
| <b>Material</b>   | Stainless Steel        |

Each meter requires 4x clips and 4x screws

## STRAIGHT CABLE ENTRY



|                   |                          |
|-------------------|--------------------------|
| <b>Order Code</b> | 10 – FL1615RGBWPFE       |
| <b>Dimensions</b> | 27.9mm x 20.4mm x 19.4mm |
| <b>Finish</b>     | Transparent              |

## END CAP



|                   |                        |
|-------------------|------------------------|
| <b>Order Code</b> | 10 – FL1615EC          |
| <b>Dimensions</b> | 26.5mm x 17mm x 24.2mm |
| <b>Material</b>   | Stainless Steel        |

espo  
LIGHTING

espo.com.au  
ABN 53 136 770 566

[joseph@espo.com.au](mailto:joseph@espo.com.au)  
+618 8117 8633